



Water Filtration System

Safety Instructions2

System Overview3-5

Installation Instructions ...6-12

Battery Installation11

Faucet Installation7, 8

Feed Water Supply6, 7

Filter Replacement12

Flush Procedure12

Installing the Tubing11

System Installation9, 10

Troubleshooting Tips13

Consumer Support

Consumer SupportBack Cover

Parts List/Catalog14

Warranty15

Owner's Manual and Installation Instructions

GNSV70RBL
GNSV75RWW



GNSV70RBL and GNSV75RWW are Tested and Certified by NSF International against NSF/ANSI Standard 42 for the reduction of Chlorine: Taste and Odor and Particulate Class I and Standard 53 for the reduction of Lead, Cyst, Turbidity, Asbestos, Mercury, Lindane, Atrazine, Benzene and VOC.

IMPORTANT SAFETY INFORMATION.

▲ WARNING: Read entire manual. Failure to follow all guides and rules could cause personal injury or property damage.

■ Check with your local public works department for plumbing codes. You must follow their guidelines as you install the Water Filtration system.

SAFETY PRECAUTIONS

■ Use the Water Filtration system on a potable, safe-to-drink, home *COLD* water supply only. The filter canisters will not purify the water, or make it safe to drink.

■ **Do not** use on a hot water supply (100°F max.). Install on a cold water line only.

▲ WARNING: *Do not use with water that is microbiologically unsafe or of unknown quality without adequate disinfection before or after the system. Systems certified for cyst reduction may be used on disinfected water that may contain filterable cysts.*

PROPER INSTALLATION

This Water Filtration system must be properly installed and located in accordance with the Installation Instructions before it is used.

▲ CAUTION: To reduce the risk of property damage due to water leakage, install or store where it will not be exposed to temperatures below freezing or exposed to any type of weather. Water freezing in the system may damage it and may result in water leakage, damaging property. Change the filter out if it was exposed to freezing temperatures. Do not attempt to treat water over 100°F.

▲ WARNING: *Discard all unused and packaging material after installation. Small parts remaining after installation could be a choke hazard.*

■ Your Water Filtration system will withstand up to 120 pounds per square inch (psi) water pressure. If your house water supply pressure is higher than 80 psi, install a pressure reducing valve before installing the Water Filtration system.

READ AND FOLLOW THIS SAFETY INFORMATION CAREFULLY.

SAVE THESE INSTRUCTIONS

Specifications Guidelines.

The Water Filtration System Uses the Following Canisters

Models GNSV70RBL and GNSV75RWW

FQSVF Filter

(160 gallon capacity)

Filter—White canisters with green band

- Reduces dirt, rust and sediment
- Reduces Chlorine: Taste and Odor
- Reduces Lead
- Reduces filterable Cysts (such as cryptosporidium and giardia)
- Reduces Turbidity
- Reduces Asbestos
- Reduces Mercury
- Reduces Lindane
- Reduces Atrazine
- Reduces Benzene
- Reduces VOC
- 0.5–1 micron nominal particulate reduction

This system conforms to NSF/ANSI 42 and 53 for the specific performance claims as verified and sustained by test data. See Performance Data Sheet for details.

Installation Overview

Locate the drinking water system on the cold water supply pipe, under the kitchen and/or bathroom sink, to filter the cold drinking water.

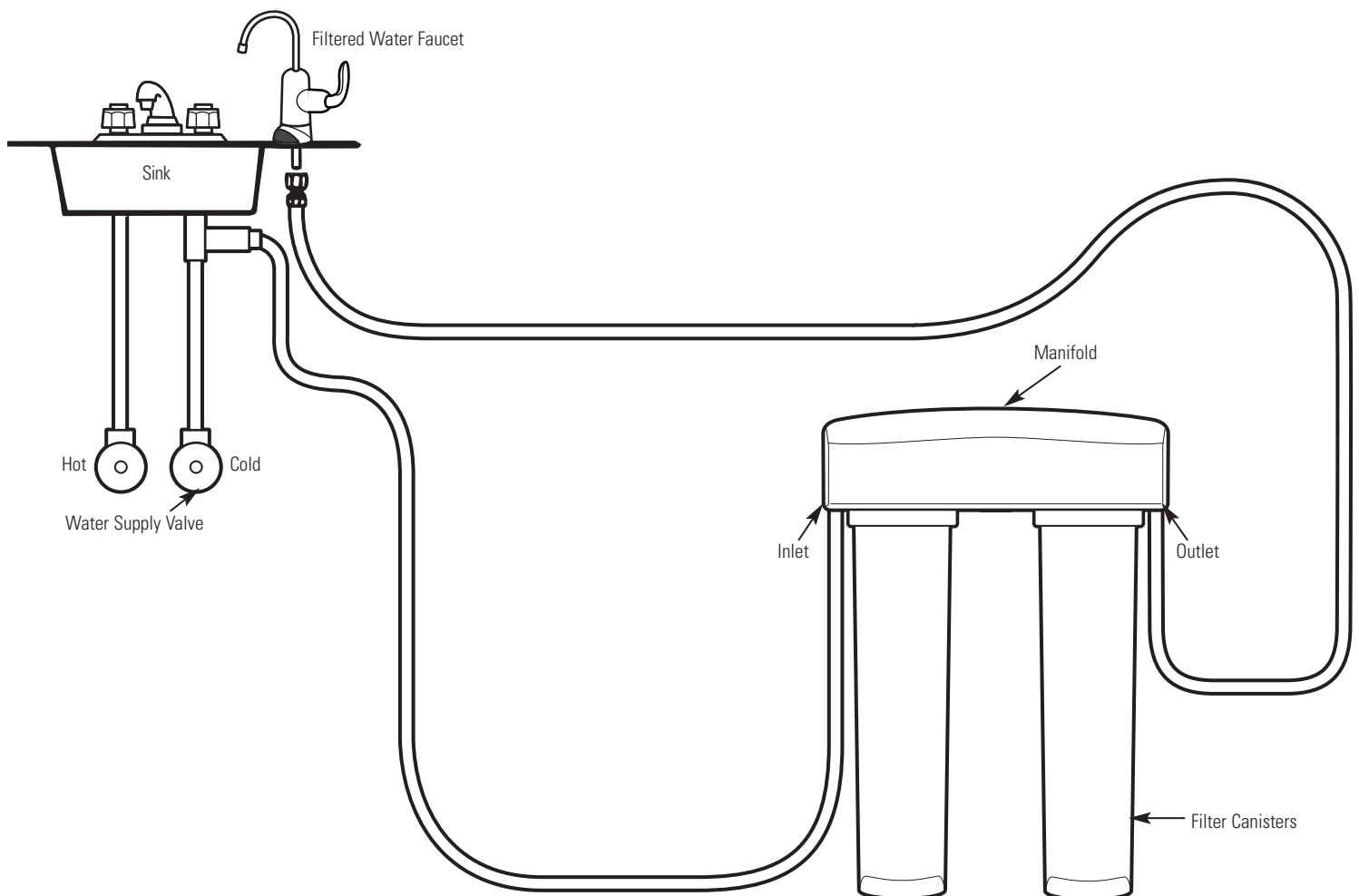

Performance Data Sheet.

SmartWater Filtration System GNSV70RBL and GNSV75RWW Using Filter FQS VF

■ This System has been tested according to NSF/ANSI 42 and 53 for the reduction of the substances listed below. The concentration of the indicated substances in water entering the system was reduced to a concentration less than or equal to the permissible limit for water leaving the system, as specified in NSF/ANSI 42 and 53.

■ Actual performance may vary with local water conditions.

▲ WARNING: Do not use with water that is microbiologically unsafe or with water of unknown quality without adequate disinfection before or after the system. Systems certified for cyst reduction may be used on disinfected waters that may contain filterable cysts.

| Standard No. 42: Aesthetic Effects | | | | | | | | |
|------------------------------------|-------------|----------------------------------|------------------|---------------|--------------|-------------|---------|---|
| Parameter | USEPA MCL | Influent Challenge Concentration | Influent Average | Effluent | | % Reduction | | Maximum Permissible Product Water Concentration |
| | | | | Average | Maximum | Average | Minimum | |
| Chlorine | — | 2.0 mg/L + 10% | 2.00 mg/L | <0.05 mg/L | <0.05 mg/L | 97.50% | 97.50% | >50% |
| T & O | — | — | — | — | — | — | — | — |
| Particulate** | — | ≥ 10000 particles | 4100000 #/mL | 76500 #/mL | 110000 #/mL | 98.10% | 97.30% | >85% |
| Standard No. 53: Health Effects | | | | | | | | |
| Turbidity | 0.5 NTU*** | 11 + 1 NTU*** | 11.0 NTU | 0.1 NTU | 0.1 NTU | 98.80% | 98.20% | 0.5 NTU |
| Cysts | 99.95% red. | Min. 50000L | 140000 #/L | 1 #/L | 1 #/L | >99.99% | >99.99% | 99.95% |
| Asbestos | 99% red. | — | 280 MF/L | <0.17 MF/L | <0.17 MF/L | >99.00% | >99.00% | 99% |
| Lead, pH 6.5 | 0.010 mg/L | 0.15 mg/L + 10% | 0.150 mg/L | <0.001 mg/L | <0.001 mg/L | >99.30% | >99.30% | 0.010 mg/L |
| Lead, pH 8.5 | 0.010 mg/L | 0.15 mg/L + 10% | 0.140 mg/L | <0.001 mg/L | <0.001 mg/L | >99.30% | >99.30% | 0.010 mg/L |
| Mercury, pH 6.5 | 0.002 mg/L | 0.006 mg/L ± 10% | 0.0065 mg/L | <0.0002 mg/L | <0.0002 mg/L | 96.60% | >96.70% | 0.002 mg/L |
| Mercury, pH 8.5 | 0.002 mg/L | 0.006 mg/L ± 10% | 0.0059 mg/L | <0.0002 mg/L | <0.0002 mg/L | 96.60% | 96.70% | 0.002 mg/L |
| Lindane | 0.0002 mg/L | 0.002 mg/L ± 10% | 0.00193 mg/L | <0.00002 mg/L | 0.00005 mg/L | >98.80% | 98.80% | 0.0002 mg/L |
| Benzene | 0.001 mg/L | 0.015 mg/L ± 10% | 0.014 mg/L | <0.0005 mg/L | <0.0005 mg/L | >96.40% | >96.40% | 0.005 mg/L |
| Atrazine | 0.003 mg/L | 0.009 mg/L ± 10% | 0.00873 mg/L | <0.0005 mg/L | <0.0005 mg/L | >94.10% | >94.10% | 0.003 mg/L |
| VOC Reduction | | | | | | | | |
| Chloroform | 0.080 mg/L | 0.300 ± 10% | 0.340 mg/L | 0.00098 mg/L | 0.00620 mg/L | 97.90% | 98.20% | 95% |

*Tested using a flow rate of 0.60 gpm (2.27 l/min); pressure of 60 psig; pH of 7.5 ± 0.5; temp. of 68° ± 5°F (20° ± 3°C)

**Measurement in particles/mL. Particles used were 0.5–1 microns.

***NTU—Nephelometric Turbidity Units

Operating Specifications

Capacity: certified for up to 160 gallons (605 l); up to six months

Pressure requirement: 35–120 psi (2.8–8.2 bar)

Temperature: 33–100°F (0.6–38°C)

Flow rate: 0.60 gpm (2.27 l/min)

Replacement Filter Canisters/Estimated Replacement Costs

FQS VF—Replacement filter canister \$35–40

For replacement parts, call toll-free 800.626.2002 (U.S.), 800.663.6060 (Canada–English), 800.361.3869 (Canada–French)

State of California
Department of Health Services
Water Treatment Device
Certificate Number
04 - 1601
Date Issued: February 9, 2009

| Trademark/Model Designation | Replacement Element(s) |
|-----------------------------|------------------------|
| GNSV65 F | FQS VF |
| GNSV65 R | FQS VF |
| GNSV70 RBL | FQS VF |
| GNSV75 RWW | FQS VF |
| GNSV65 R | FQS VF |
| GNSV75 RWW | FQS VF |
| GNSV70 RBL | FQS VF |

Manufacturer: General Electric Company

The water treatment device(s) listed on this certificate have met the testing requirements pursuant to Section 116830 of the Health and Safety Code for the following health related contaminants:

| Microbiological Contaminants and Turbidity | Inorganic/Radiological Contaminants |
|--|---|
| Cysts Turbidity | Asbestos Lead Mercury |
| Organic Contaminants | |
| Atrazine Lindane Benzene VOCs Alachlor Atrazine Benzene Carbofuran Carbon Tetrachloride Chlorobenzene Chloroacetic 2,4-D DIBCP o-Dichlorobenzene p-Dichlorobenzene 1,2-Dichloroethane 1,1-Dichloroethylene cis-1,2-Dichloroethylene trans-1,2-Dichloroethylene 1,2-Dichloropropane cis-1,3-Dichloropropene Dioxin | Endrin Dibenzene EDB Halocarbonates (HAC) Hexachlorocyclopentadiene Hexachlorocyclopentadiene Hexachlorocyclopentadiene Hexachlorocyclopentadiene Lindane Methoxychlor Permethrin Simazine Styrene 1,1,2,2-Tetrachloroethane Tetrahydrofuran Toluene 2,4,5-TP (Silvex) Trifluoroacetic Acid 1,1,1-Trichloroethane 1,1,2-Trichloroethane Trichloroethylene Trichloroethylene (TCE) Bromochloroacetic acid Bromofuran Chloroform Chlorodibromomethane Xylenes |

Rated Service Capacity: 160 gal Rated Service Flow: 0.6 gpm

Do not use where water is microbiologically unsafe or with water of unknown quality, except that systems certified for cyst reduction may be used on disinfected waters that may contain filterable cysts.

IOWA RESIDENTS ONLY:

Store or Seller's Name

Address

City

State

Zip

Telephone

Seller's signature

Customer's signature

Date

Performance Data Sheet.

Organic Chemicals Reduced by Chloroform Surrogate Testing

| Contaminant | Avg. ¹ Influent (µg/L) ² | Max. Effluent (µg/L) ² |
|-----------------------------|---|--------------------------------------|
| Alachlor | 50 | 1.0 ³ |
| Atrazine | 100 | 3.0 ³ |
| Benzene | 81 | 1.0 ³ |
| Carbofuran | 190 | 1.0 ³ |
| Carbon Tetrachloride | 78 | 1.8 ⁴ |
| Chlorobenzene | 77 | 1.0 ³ |
| Chloropicrin | 15 | 0.2 ⁴ |
| 2,4-D | 110 | 1.7 ⁴ |
| Dibromochloropropane (DBCP) | 52 | 0.02 ³ |
| o-Dichlorobenzene | 80 | 1.0 ³ |
| p-Dichlorobenzene | 40 | 1.0 ³ |
| 1,2-Dichloroethane | 88 | 4.8 ⁵ |
| 1,1-Dichloroethylene | 83 | 1.0 ³ |
| cis-1,2-Dichloroethylene | 170 | 0.5 ³ |
| trans-1,2-Dichloroethylene | 86 | 1.0 ³ |
| 1,2-Dichloropropane | 80 | 1.0 ³ |
| cis-1,3-Dichloropropylene | 79 | 1.0 ³ |
| Dinoseb | 170 | 0.2 ⁴ |
| Endrin | 53 | 0.59 ⁴ |
| Ethylbenzene | 88 | 1.0 ³ |
| Ethylene Dibromide (EDB) | 44 | 0.02 ³ |
| Haloacetonitriles (HAN): | | |
| Bromochloroacetonitrile | 22 | 0.5 ⁴ |
| Dibromoacetonitrile | 24 | 0.6 ⁴ |
| Dichloroacetonitrile | 9.6 | 0.2 ⁴ |
| Trichloroacetonitrile | 15 | 0.3 ⁴ |

¹ Influent challenge levels are average influent concentrations determined in surrogate qualification testing.

² µg/L means Micrograms Per Liter.

³ Maximum product water level was not observed but was set at the detection limit of the analysis.

⁴ Maximum product level is set at a value determined in surrogate qualification testing.

⁵ Chemical reduction percent and maximum product water level calculated at chloroform 95% breakthrough point as determined in surrogate qualification testing.

⁶ The surrogate test results for heptachlor Epoxide demonstrated a 98% reduction. These data were used to calculate an upper occurrence concentration, which would produce a maximum product water level at the MCL.

Testing was performed under standard laboratory conditions; actual performance may vary.

NOTE: Substances reduced are not necessarily in your water. Filter must be maintained according to manufacturer's instructions, including replacement of filter cartridges.

▲ WARNING: Do not use with water that is microbiologically unsafe or of unknown quality without adequate disinfection before or after the system. Systems certified for cyst reduction may be used on disinfected waters that contain filterable cysts.

Installation Instructions

Faucet Mount Filtration System –

GNSV70RBL and GNSV75RWW

IMPORTANT INSTALLATION RECOMMENDATIONS

⚠ WARNING – Read entire manual. Failure to follow all guides and rules could cause personal injury or property damage.

- Check with your local public works department for plumbing codes. You must follow their guides as you install the Water Filtration system.

TOOLS AND MATERIALS REQUIRED FOR INSTALLATION

- Phillips screwdriver
- Two (2) adjustable wrenches
- Electric drill and drill bit to drill 1" hole (type as required) if mounting hole is needed for faucet
- Tape measure
- If your main water line is a rigid pipe, you will require a compression fitting and possibly other plumbing hardware to complete the installation.

⚠ CAUTION – To avoid damaging the sink, consult a qualified plumber or installer for drilling procedures. Special drill bits may be needed for porcelain or stainless steel.

CONTENTS INCLUDED WITH THE PRODUCT

- Water filter system assembly, including mounting screws
- Feed water adapter
- Faucet assembly with electronic base monitor and tubing

COLD WATER SUPPLY FITTING

A. PREFERRED INSTALLATION

(Utilizing existing kitchen sink water supply valve and flexible faucet tubing)

A typical connection using the included water supply fitting is shown in the illustration below.

1. Close the water shut-off valve that is immediately in front of the supply tube and open the faucets to drain water from the sink cold water pipe.
2. Remove the nut that connects the cold water faucet to the supply tube. Some water may spill out.

NOTES:

- Be sure to turn off the water supply and open a faucet to drain the pipe.
- Make sure the gasket is installed in the water supply fitting.

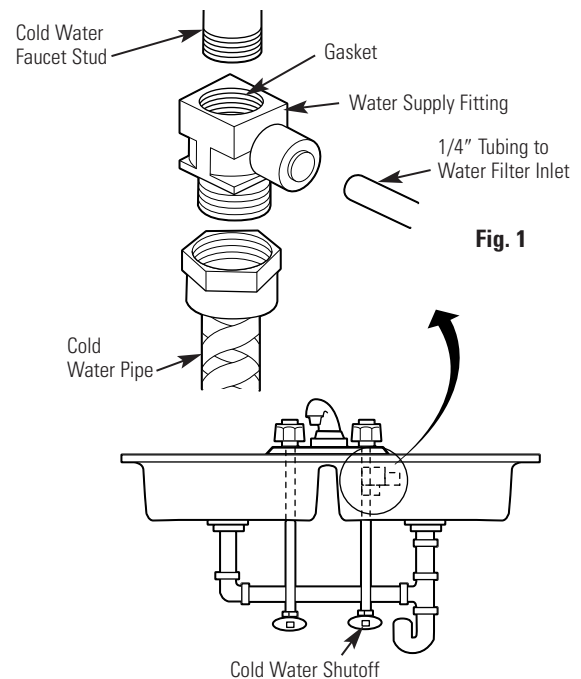

3. Hand-tighten the water supply fitting onto the cold water faucet. Be sure the gasket, as shown, is in place before final assembly. Finish tightening with an adjustable wrench. **Be careful not to overtighten or cross-thread, as damage to the threads can occur.** Make sure the 1/4" quick connection is not against a wall that causes the supply tubing connection to bend. A quarter turn to tighten or loosen the adapter may be necessary to avoid this.
4. Reconnect faucet tubing line to the fitting.
5. Install tubing. (See Installing the Tubing section.)

Installation Instructions

COLD WATER SUPPLY FITTING (CONT.)

B. OPTIONAL HOME INSTALLATION

(Where codes permit)

Saddle Valve: Saddle valve must be able to connect with 1/4-inch tubing supplied with the system. Not supplied with product; check your local hardware or home service store for product. Saddle valve typically requires 1/2" OD tubing or larger.

NOTE: Codes in the state of Massachusetts require installation by a licensed plumber and do not permit the use of the saddle valve. For installation, use plumbing code 248-CMR of the Commonwealth of Massachusetts.

1. Turn off the cold water supply and install saddle valve as required by product selection. (Be sure to follow manufacturer's installation instructions.)

⚠ DANGER — If hole is required to be drilled in pipe, to protect yourself from serious injury or fatal shock, use a battery-powered hand drill only to make the hole. DO NOT USE AN ELECTRIC DRILL.

2. Open saddle valve after complete system has been installed.

C. OPTIONAL INSTALLATION

(For installation with rigid pipe between supply valve and sink faucet)

Option 1

1. Remove pipe from supply valve and sink faucet.
2. Obtain flexible pipe sized to your plumbing.
3. Install flexible pipe.
4. Go back to A. Preferred Installation section step 3.

Option 2

1. Obtain compression fittings to fit rigid pipe.
2. Obtain any other fittings required to connect compression fittings to feed water adapter.
3. Remove pipe from supply valve.
4. Cut pipe to fit length of assembled fittings and adapter.
5. Install compression fitting to pipe.
6. Go back to A. Preferred Installation section step 3.

NOTE: Above described materials are not included with the product.

INSTALL THE FAUCET

Be sure there is room underneath and above the sink to make the needed connections. Before starting, make sure there is sufficient room for the faucet base and unit. Select one of the following places to install the faucet:

- A. In an existing sink spray attachment or soap dispenser hole.
- B. In a hole to be drilled in the sink top.
- C. In a hole to be drilled in the countertop, next to the sink.

NOTES:

- Be sure the faucet base will fit flat against the surface at the selected location so the bottom gasket between the base and surface area will seal.
- Make sure to leave enough clearance at the back of the faucet in case you need to remove it.

Installation Steps (refer to illustration below for clarification)

1. If drilling is needed, make a 1" diameter hole. **Be sure to use the proper procedure for drilling porcelain or stainless steel. Special drill bits may be needed. Consult a qualified plumber for the proper procedure.**

⚠ CAUTION: When drilling in Stainless Steel, the edges may be sharp and could puncture the tube. Be careful to not cut yourself or damage the tube.

2. Remove the faucet body and base by turning the base counterclockwise.
3. Remove the butterfly bracket from the screw. Then insert the screw into the top of the base and reattach the butterfly bracket.
4. Align the gasket to cover the hole completely. Then place the butterfly bracket on the base into the hole.

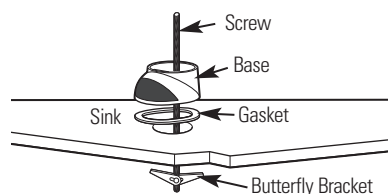

5. Tighten the screw to secure the butterfly bracket to the underside of the sink top. The base should be firmly in place and should not wobble or turn.

Installation Instructions

INSTALL THE FAUCET (CONT.)

6. Feed the water tube up through the faucet base. Then push the tube into the fitting on the bottom of the faucet body. It should go in about 3/4". Pull tube slightly to make sure it is secure.

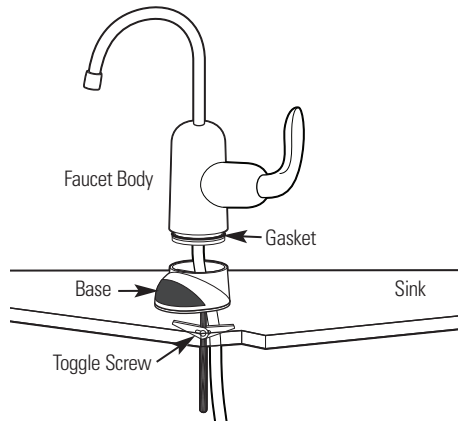

7. Push the faucet body down into the faucet base and twist clockwise until it clicks into place.

NOTE: You can install the faucet so the handle is on the right or the left side.

If you want the faucet handle on the right, position the handle at the back of the faucet base before turning clockwise.

If you want the faucet handle on the left, position the handle at the front of the faucet base before turning clockwise.

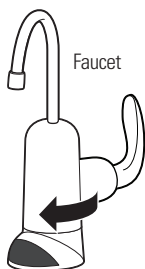

Faucet handle on the RIGHT

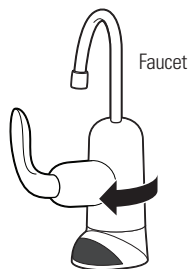

Faucet handle on the LEFT

8. Locate the hole at the rear of the base. Insert set screw and begin to tighten by hand. Finish tightening with the allen wrench provided in the packet.

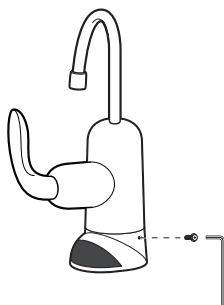

Installation Instructions

MOUNTING SYSTEM INSTALLATION

Pick a location under the sink to mount the system. Location should be easily accessible, with clearance between the bottom of the filter canisters and the floor or bottom of the cabinet; any less will result in difficulty of removing filter canisters (see Fig. 5). Allow enough space on either side of the system for the tubing connections.

SCREW INSTALLATION

1. Remove this template from the manual for easier installation.
2. The top of the template openings should be placed a minimum of 17 inches above the bottom of the cabinet or floor where the system is to be mounted (Fig. 4 and 5). **NOTE:** Any distance lower may result in filter canisters interfering with the floor when removed.
3. Tape template to wall, then mark the wall where the screws are to be installed.

Install screws into the wall, leaving 3/16 inch clearance between the head of the screw and wall (drill pilot holes if needed) (Fig. 6).

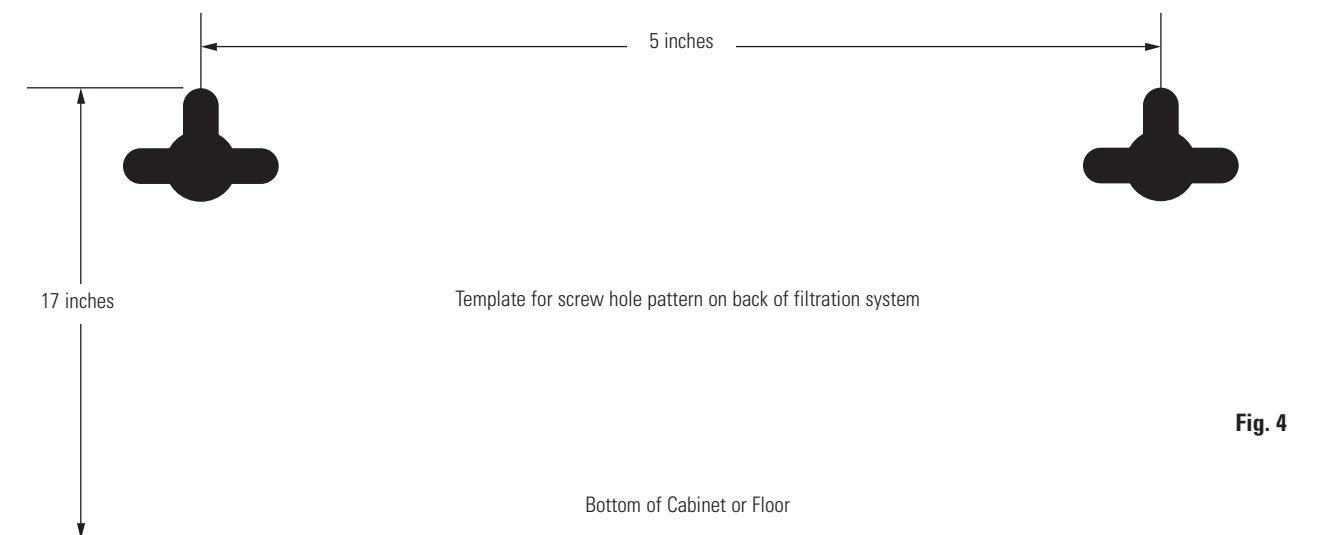

Fig. 4

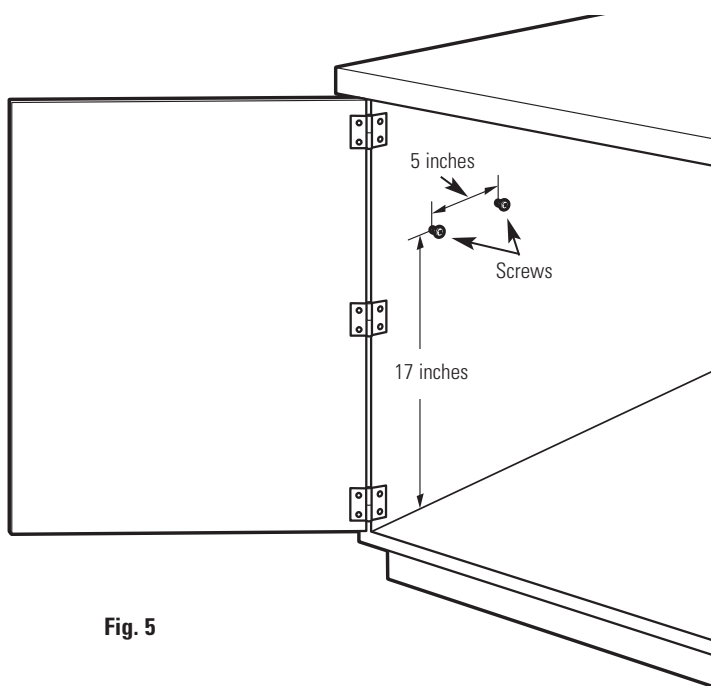

Fig. 5

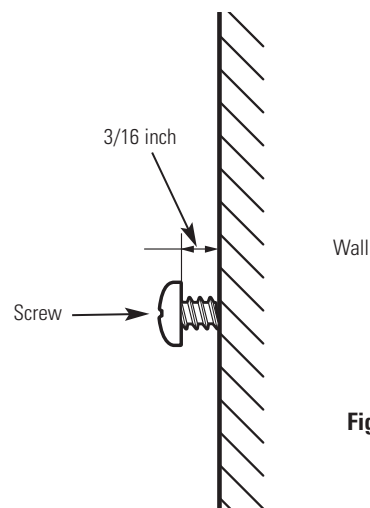

Fig. 6

Installation Instructions

MOUNTING SYSTEM INSTALLATION (CONT.)

Mounting System to Screws Installed in Wall

1. Remove shrink wrap from filter system.
2. Hang the system on the previously installed screws using the openings on the back of the unit (Fig. 7).
3. If the head of the screw will not slide into the upper slot, back out the screw by 1/4 turn and try again.
4. If the system is too loose when placed on the wall, tighten the screws by 1/4 turn and try again until a desired fit is achieved.

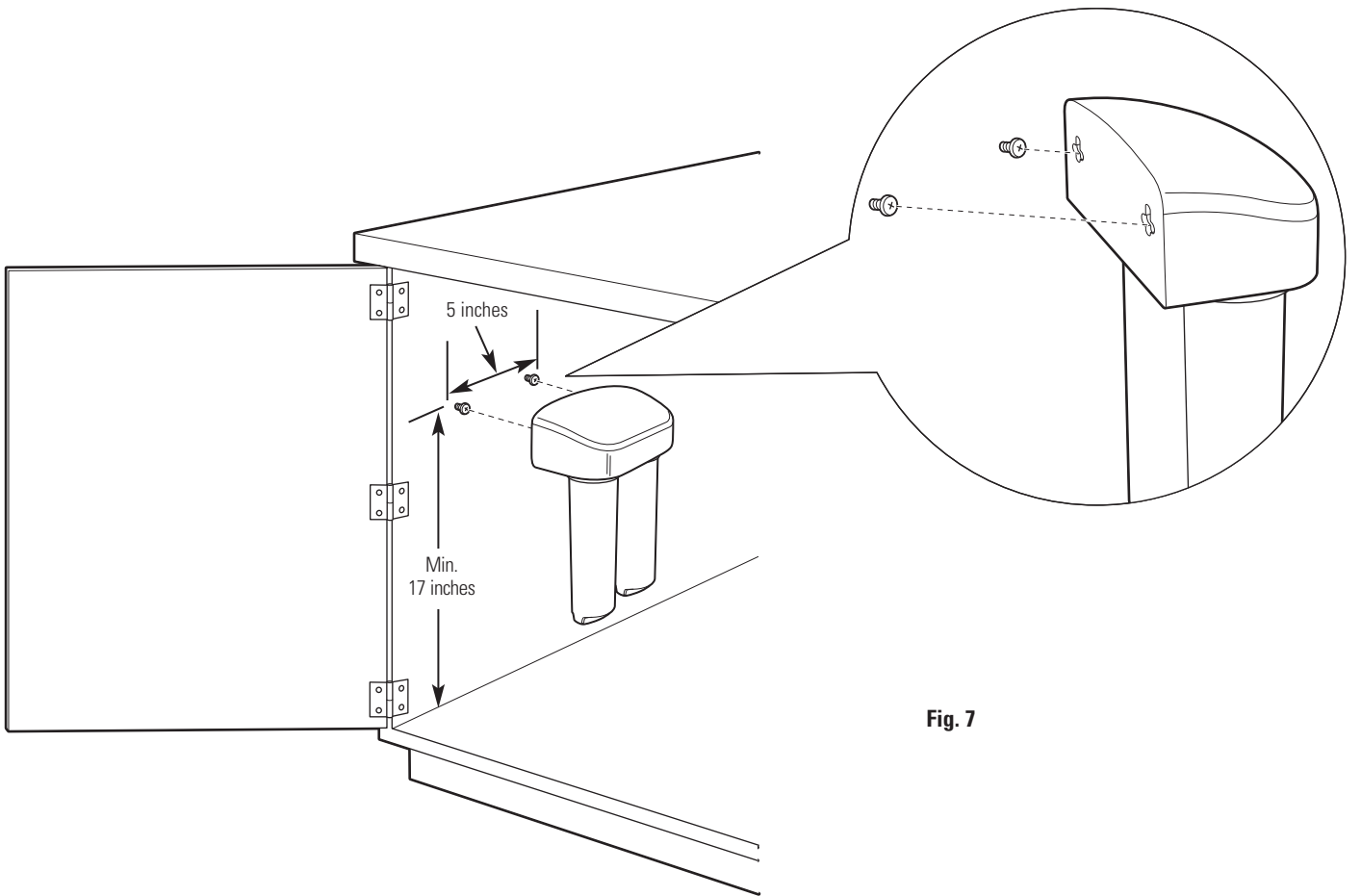

Fig. 7

Installation Instructions

INSTALLING THE TUBING

1. Measure $\frac{3}{4}$ " from the end of each remaining piece of tubing (faucet end and inlet end) and mark with a pencil (Fig. 8). (Check for roundness, smoothness, cuts, nicks, flat spots and sharp edges. It may be necessary to recut the tubing.)

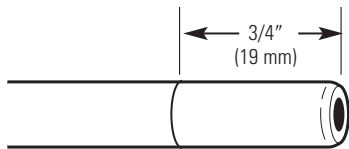
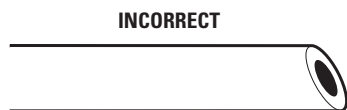
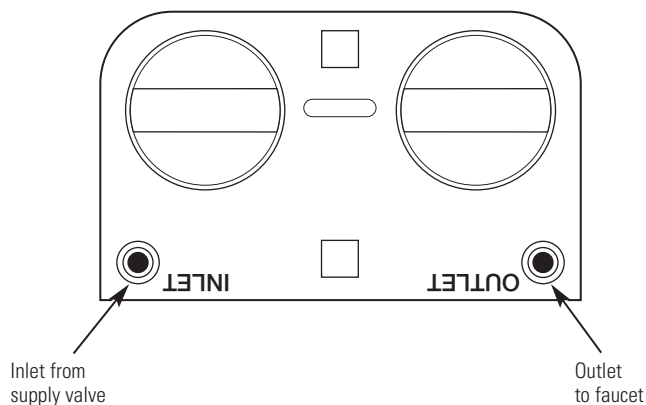

Fig. 8



2. Locate fittings for tubing on bottom of manifold.



3. **NOTE: Water flow is from left to right. Water inlet is on the left side and water outlet is on the right side. Failure to follow will result in water leaks when filter canisters are removed.**

4. Push the tubing firmly into each fitting on the manifold until the line is flush with the fitting collar. (If the tubing is removed, re-cut the end, measure, mark and re-insert). Tubing must be fully inserted to avoid leaks (Fig. 9). (To remove tubing, depress and hold white collet; pull tubing out to remove.)

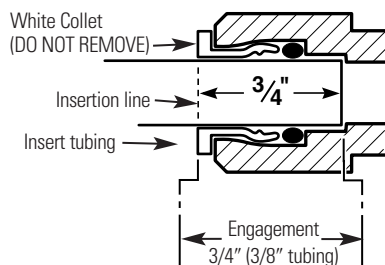

Fig. 9

INSTALLING THE TUBING (CONT.)

5. Pull out slightly on tubing to ensure a good seal.
6. Install the other end of the tubing from the inlet side of the manifold to the feed water adapter.

NOTE: Inspect the ends of the tubing to be sure there are no imperfections and that the end of the tubing is cut square. It may be necessary to cut the tubing again.

INSTALL THE BATTERY

1. Remove the lens cover from the faucet base. Grip it from both sides and pull forward.
2. Install one CR2032 3V battery with the "+" side down into the battery tray.
3. The amber LED light will flash 5 times, indicating a proper installation and system reset. If the amber light does not flash, check the position of the battery and make sure it is installed correctly.
4. Slide the lens cover back into the faucet base.
5. Normally, the light is off. After 6 months of use, the amber LED light will flash every 30 seconds, indicating the time to replace the filter canister.

NOTE: The amber LED light may stop blinking if it is allowed to blink for an extended period of time. To ensure proper operation, the battery should be replaced with every filter change.

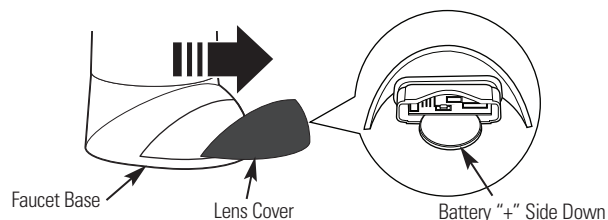

Installation Instructions

REPLACING THE FILTER CANISTERS

The amber light in the faucet base will flash every 30 seconds to indicate a filter change is needed. This occurs every 6 months. TO PROPERLY MAINTAIN THE SYSTEM, CHANGE THE FILTER AS REQUIRED.

1. Remove the filter canisters from the manifold by rotating the canisters to the left about 1/3 turn (Fig. 11). **NOTE:** A small amount of water from the tubing between the filter and the faucet may come out. A small towel should be able to catch it.
2. Remove foil on top of new replacement filter canisters. Install the new canisters into the manifold by turning to the right about 1/3 turn until the alignment marks line up and the filter stops. **DO NOT OVERTIGHTEN.** The filter will rise up as it is turned.
3. Turn handle on faucet to allow trapped air to purge from the system.

NOTE: System may make noise during this procedure.

4. Check for water leaks around the system.
5. Once water starts to flow out of the faucet, allow the system to run for 3 gallons (or 5 minutes) to flush out any harmless carbon fines that may be present.
6. Turn off faucet and check around system for leaks.
7. Remove battery tray and replace battery to reset timer. (See *Battery Installation* for proper procedure.)

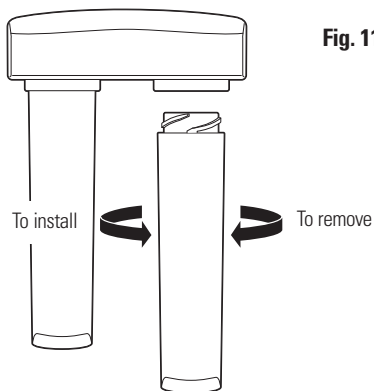

Replacement Filter Canisters/ Estimated Replacement Costs

FQSVF—Replacement filter canister \$35–\$40

For replacement parts, call toll-free 800.626.2002 (U.S.), 800.663.6060 (Canada–English), 800.361.3869 (Canada–French).

FLUSH PROCEDURE

Whenever water of unknown quality is passed through the GE Water Filtration system, the filter canisters should be discarded and the filtration system flushed.

⚠ WARNING: Do not use with water that is microbiologically unsafe or of unknown quality without adequate disinfection before or after the system. Systems certified for cyst reduction may be used on disinfected water that may contain filterable cysts.

Circumstances that may require flushing the system are:

- Boil water advisory
- Flooding of the GE Water Filtration system
- Long-term non-use

The procedure for flushing the GE Water Filtration system is:

1. See *Replacing the Filter Canisters* section and follow steps 1–5.

Before you call for service...



*Troubleshooting Tips
Save time and money! Review the chart
below first and you may not need to call
for service.*

| Problem | Possible Causes | What To Do |
|--|---|--|
| Water contains tiny black particles | New filter canisters contain activated carbon. | <ul style="list-style-type: none"> • Turn on the filtered water faucet and allow these initial carbon particles to purge from the canisters. Turn off the faucet when the water is clear. |
| Water has air bubbles and is cloudy | Air in system after installation. | <ul style="list-style-type: none"> • Will go away after water runs for a while. |
| Indicator light on the faucet base is flashing | Six months usage has occurred. This is the maximum life of the filter canisters. | <ul style="list-style-type: none"> • Replace both filter canisters and battery in the faucet base. |
| Indicator light on the faucet base is not blinking | <p>Normal operation.</p> <p>Battery may need to be replaced.</p> | <ul style="list-style-type: none"> • Does not blink until 6 months of operation has passed. • Normally the light is not on. The light blinks every 30 seconds to indicate a filter change is needed. This occurs about every 6 months. • Replace battery. Indicator light will blink rapidly 5 times to indicate proper installation and operation. |
| Indicator light on the faucet base is not working when new battery is installed | Battery may need to be replaced or it may have been installed incorrectly. | <ul style="list-style-type: none"> • Observe orientation markings on the holder. Install with battery "+" side down. |
| Chlorine taste and/or odor in the product water | The filter canisters are no longer reducing chlorine, taste and odor from the water supply. | <ul style="list-style-type: none"> • Replace the filter canisters. |
| Water dispenses very slowly | <p>The filters have been installed for too long.</p> <p>The filter canisters have become clogged.</p> | <ul style="list-style-type: none"> • A six-month change-out period is recommended. Replace both filter canisters. • High sediment levels can cause premature clogging. Replace both filter canisters. |
| Fittings are leaking | Tubing may not be installed properly. | <ul style="list-style-type: none"> • Fully follow the installation instructions and be sure the tubing is free of nicks, burrs, etc., and is installed to the proper depth. |
| No water dispensing from system | Filter canisters not fully installed. | <ul style="list-style-type: none"> • Fully follow the filter replacement instructions. |

Parts List.

GNSV70RBL, GNSV75RWW

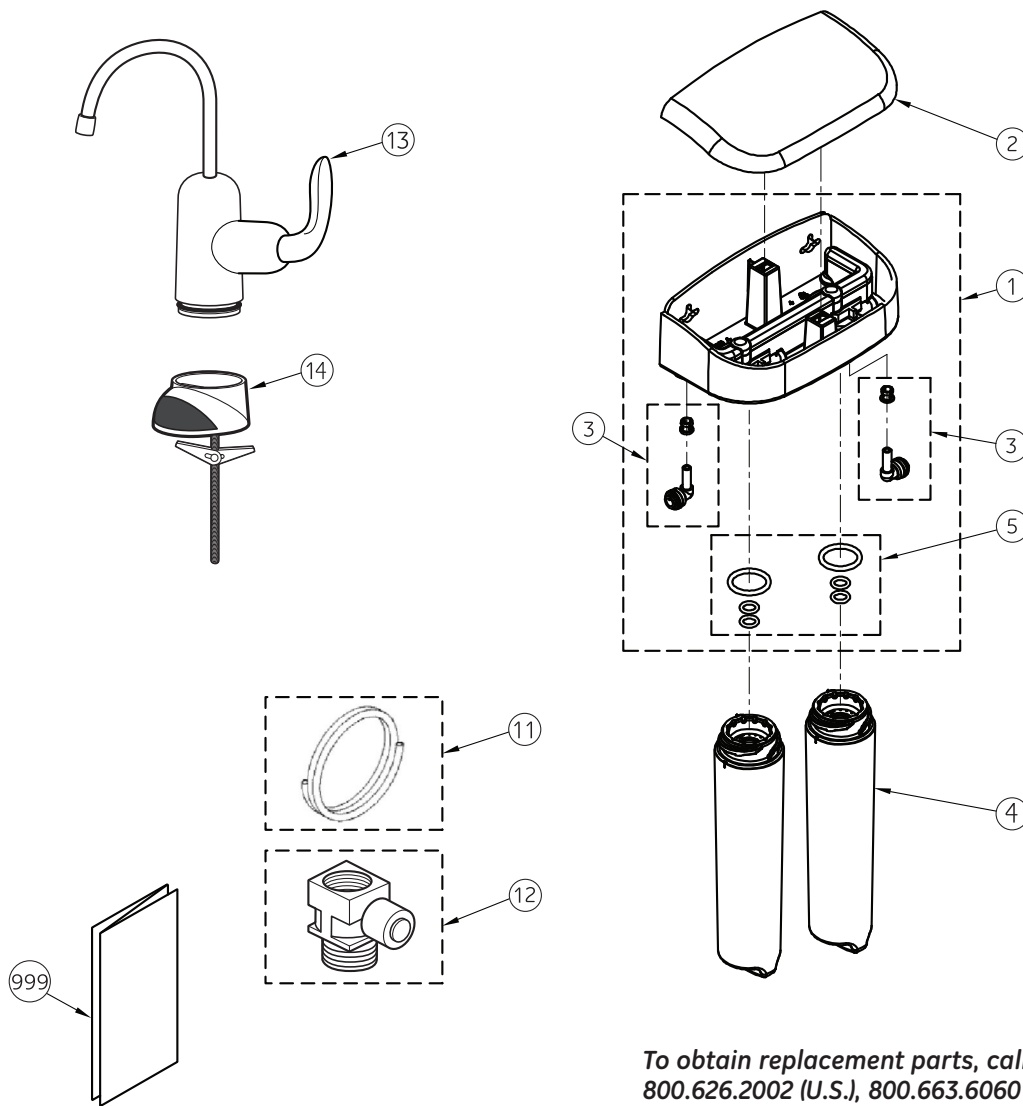

To obtain replacement parts, call toll-free
 800.626.2002 (U.S.), 800.663.6060 (Canada-
 English), 800.361.3869 (Canada-French)

General Electric parts catalog.

| ITEM | GE CAT. NO. | DESCRIPTION | GNSV70RBL | GNSV75RWW |
|------|-------------|-------------------------------|-------------|-------------|
| | | | (00) QTY | (00) QTY |
| 1 | WS19X10016 | MANIFOLD ASSEMBLY | 1 | 1 |
| 2 | WS19X10015 | COVER, DUAL MANIFOLD | 1 | 1 |
| 3 | WS22X10045 | ELBOW & COLLET | 2 | 2 |
| 4 | FQSVF | FILTER SET (VOC) | 1 | 1 |
| 5 | WS03X10046 | O-RING KIT (2 LG, 4 SM) | 1 | 1 |
| 11 | WS07X10020 | TUBING—6'0" | 1 | 1 |
| 12 | WS60X10016 | INLET ADAPTER—NO VALVE | 1 | 1 |
| 13 | WS15X10068 | FAUCET BODY, CHROME | 1 | - |
| 13 | WS15X10069 | FAUCET BODY, WHITE | - | 1 |
| 14 | WS10X10039 | FAUCET BASE, CHROME | 1 | - |
| 14 | WS10X10040 | FAUCET BASE, WHITE | - | 1 |
| 999 | 49-50234 | OWNER'S MANUAL & INST. INSTR. | 1 | 1 |

GE Water Filtration System Warranty.



All warranty service provided by our SmartWater™ Authorized Servicer Network. To schedule service, on-line, visit us at GEAppliances.com, or call 800.952.5039 in the U.S., or toll-free 866.777.7627 in Canada. Please have serial number and model number available when calling for service.

Staple your receipt here.
Proof of the original purchase date is needed to obtain service under the warranty.

For The Period Of: **GE Will Replace:**

One Year

From the date of the original purchase

Any part of the Water Filtration System (excluding filters) which fails due to a defect in materials or workmanship. During this **limited one-year warranty**, GE will also provide, **free of charge**, all labor and related service to replace the defective part.

What GE Will Not Cover:

- Service trips to your home to teach you how to use the product.
- Improper installation, delivery or maintenance.
- Failure of the product if it is abused, misused, or used for other than the intended purpose or used commercially.
- Use of this product where water is microbiologically unsafe or of unknown quality, without adequate disinfection before or after the system. Systems certified for cyst reduction may be used on disinfected water that may contain filterable cysts.
- Filter cartridges and batteries after 30 days from date of purchase.
- Damage to the product caused by accident, fire, floods or acts of God.
- Incidental or consequential damage caused by possible defects with this appliance.

EXCLUSION OF IMPLIED WARRANTIES—Your sole and exclusive remedy is product repair as provided in this Limited Warranty. Any implied warranties, including the implied warranties of merchantability or fitness for a particular purpose, are limited to one year or the shortest period allowed by law.

This warranty is extended to the original purchaser and any succeeding owner for products purchased for home use within the USA. If the product is located in an area where service by a GE Authorized Servicer is not available, you may be responsible for a trip charge or you may be required to bring the product to an Authorized GE Service location for service. In Alaska, the warranty excludes the cost of shipping or service calls to your home.

Some states do not allow the exclusion or limitation of incidental or consequential damages. This warranty gives you specific legal rights, and you may also have other rights which vary from state to state. To know what your legal rights are, consult your local or state consumer affairs office or your state's Attorney General.

Warrantor: General Electric Company. Louisville, KY 40225

Consumer Support.



GE Appliances Website

GEAppliances.com

Have a question or need assistance with your appliance? Try the GE Appliances Website 24 hours a day, any day of the year! For greater convenience and faster service, you can now download Owner's Manuals, order parts or even schedule service on-line.



Schedule Service

GEAppliances.com

Expert GE repair service is only one step away from your door. Get on-line and schedule your service at your convenience any day of the year! Or call 800.GE.CARES (800.432.2737) during normal business hours.



Real Life Design Studio

GEAppliances.com

GE supports the Universal Design concept—products, services and environments that can be used by people of all ages, sizes and capabilities. We recognize the need to design for a wide range of physical and mental abilities and impairments. For details of GE's Universal Design applications, including kitchen design ideas for people with disabilities, check out our Website today. For the hearing impaired, please call 800.TDD.GEAC (800.833.4322).



Extended Warranties

GEAppliances.com

Purchase a GE extended warranty and learn about special discounts that are available while your warranty is still in effect. You can purchase it on-line anytime, or call 800.626.2224 during normal business hours. GE Consumer Home Services will still be there after your warranty expires.

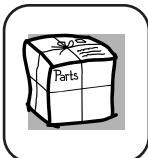

Parts and Accessories

GEAppliances.com

Individuals qualified to service their own appliances can have parts or accessories sent directly to their homes (VISA, MasterCard and Discover cards are accepted). Order on-line today, 24 hours every day or by phone at 800.626.2002 during normal business hours.

Instructions contained in this manual cover procedures to be performed by any user. Other servicing generally should be referred to qualified service personnel. Caution must be exercised, since improper servicing may cause unsafe operation.



Contact Us

GEAppliances.com

If you are not satisfied with the service you receive from GE, contact us on our Website with all the details including your phone number, or write to:

General Manager, Customer Relations
GE Appliances, Appliance Park
Louisville, KY 40225



Register Your Appliance

GEAppliances.com

Register your new appliance on-line—at your convenience! Timely product registration will allow for enhanced communication and prompt service under the terms of your warranty, should the need arise. You may also mail in the preprinted registration card included in the packing material.